

DO NOT SCALE DRAWING
 DIMENSIONS GIVEN IN
 PARENT AND 1/16 OF
 INCHES UNLESS OTHERWISE
 SPECIFIED
 ALL DIMENSIONS TO BE
 TO CENTER UNLESS OTHERWISE
 SPECIFIED

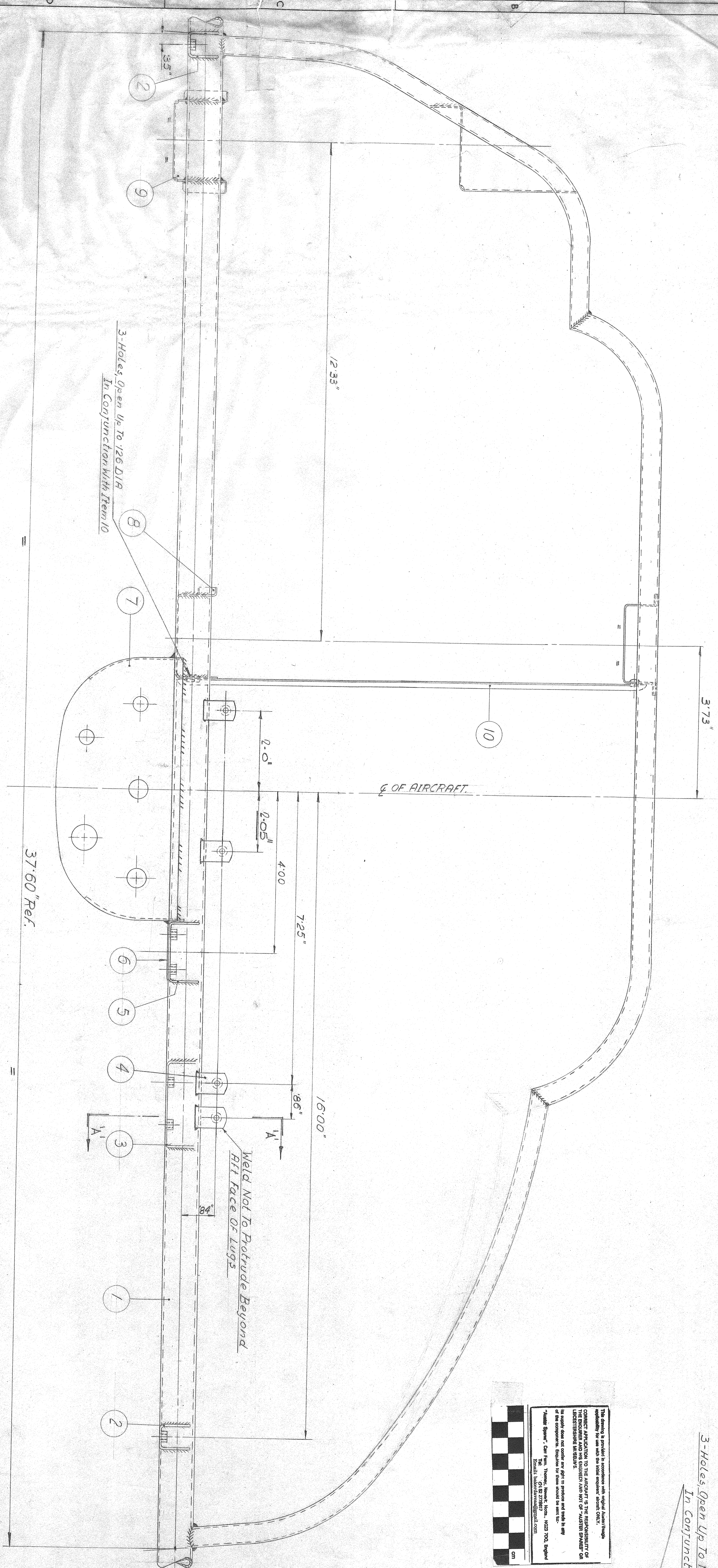

Note:
 Weld Where Marked Thus:

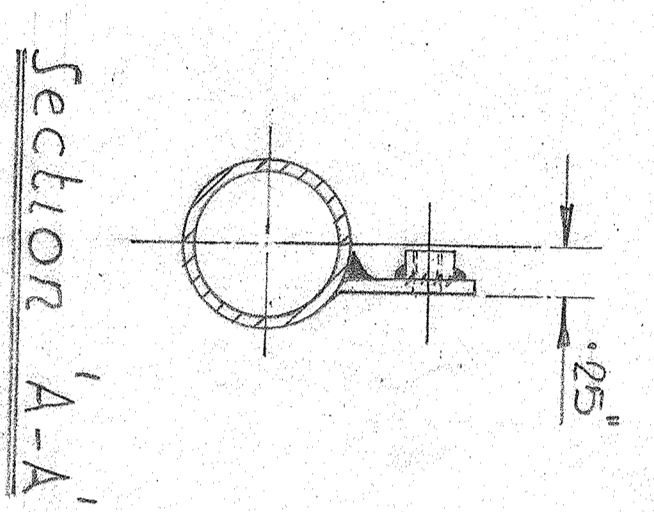

VIEW ON RHT FACE

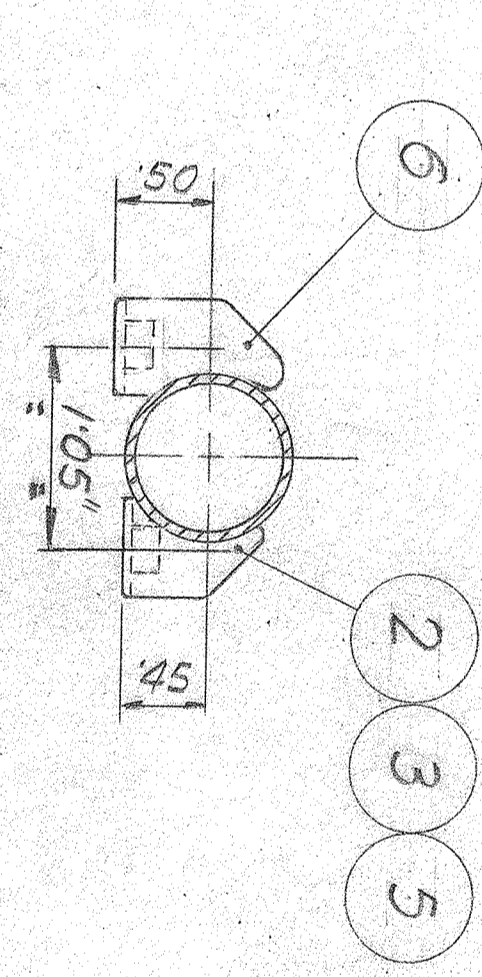
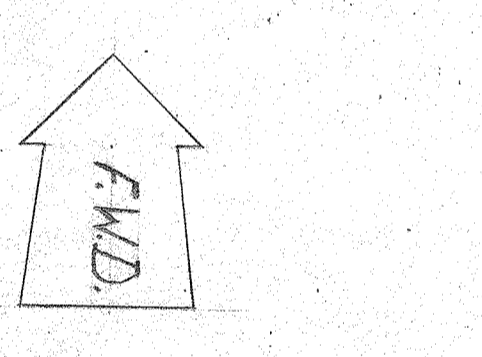

Part Section Showing Position
 Of Items: 2, 3, 5, 6

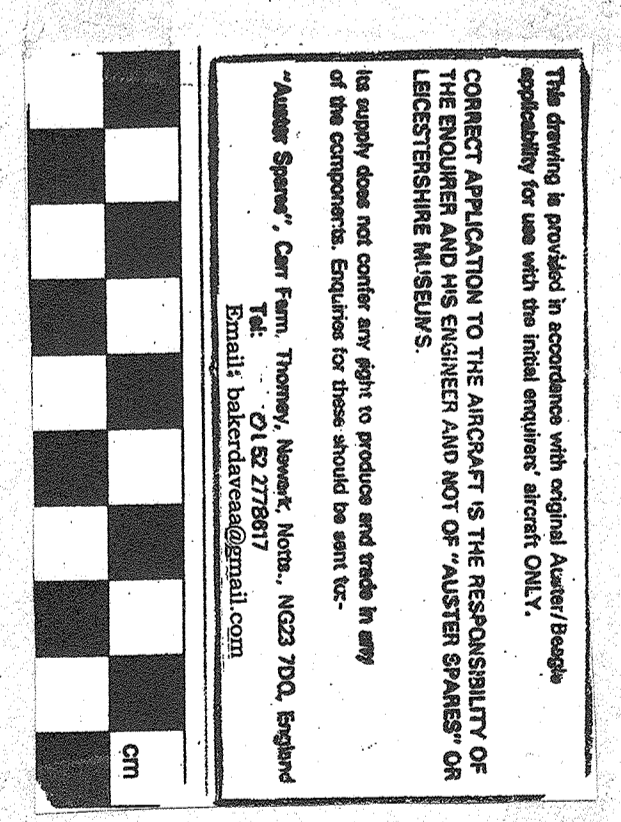

3-Holes Open Up To No 300
 In Conjunction With Item 11

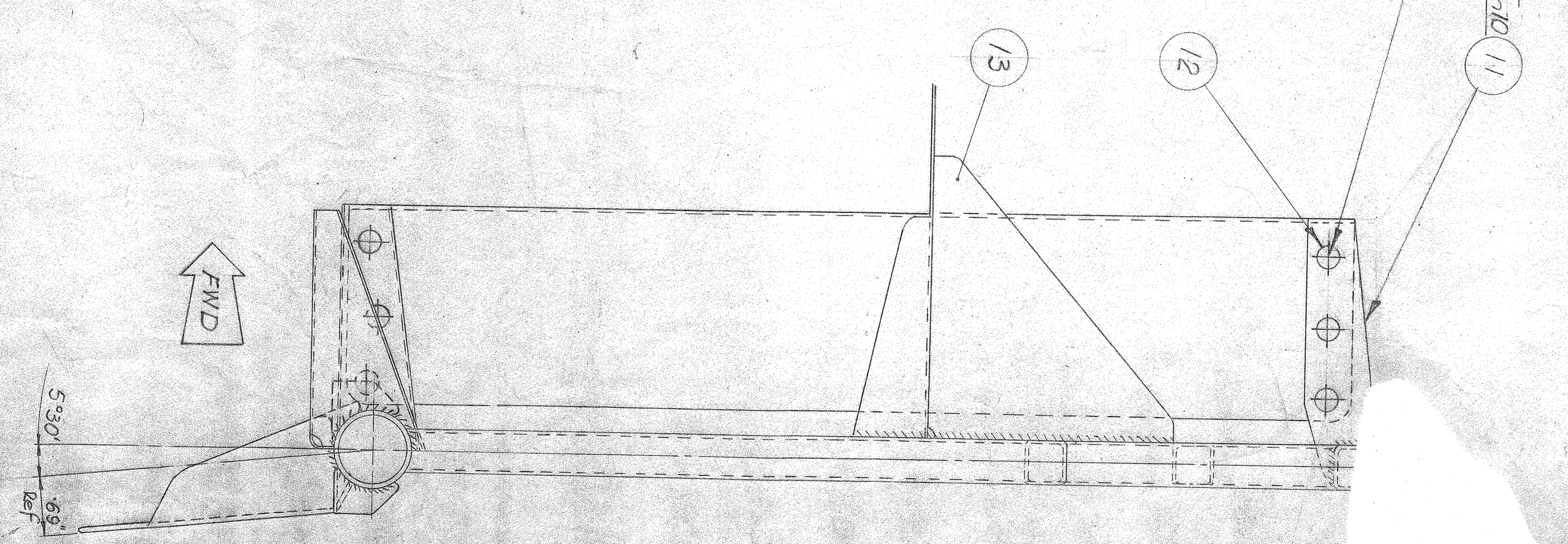

REV	DATE	BY	CHKD	DESCRIPTION
20				
19				
18				
17				
16				
15				
14				
13				
12				
11				
10				
9				
8				
7				
6				
5				
4				
3				
2				
1				

REV	DATE	BY	CHKD	DESCRIPTION
20				
19				
18				
17				
16				
15				
14				
13				
12				
11				
10				
9				
8				
7				
6				
5				
4				
3				
2				
1				

PROBING TREATMENT
 R/A
 SCALE 1/16
 DRAWING NO. 41694102
 ISSUE A
 TITLE BOW & CROSS TUBE ASSY
 BEAGLE AIRCRAFT LIMITED LEICESTER
 PART NO. 1A 16-30
 ENG. 3/25