

1. DO NOT SCALE DRAWING
 2. ENGLISH PROJECTION IS USED UNLESS OTHERWISE STATED.
 3. TOLERANCES ON DIMENSIONS ARE + OR - .01 UNLESS OTHERWISE STATED.
 4. IF IN DOUBT ABOUT THIS DRAWING, RING DRAWING OFFICE BEFORE COMMENCING OPERATIONS

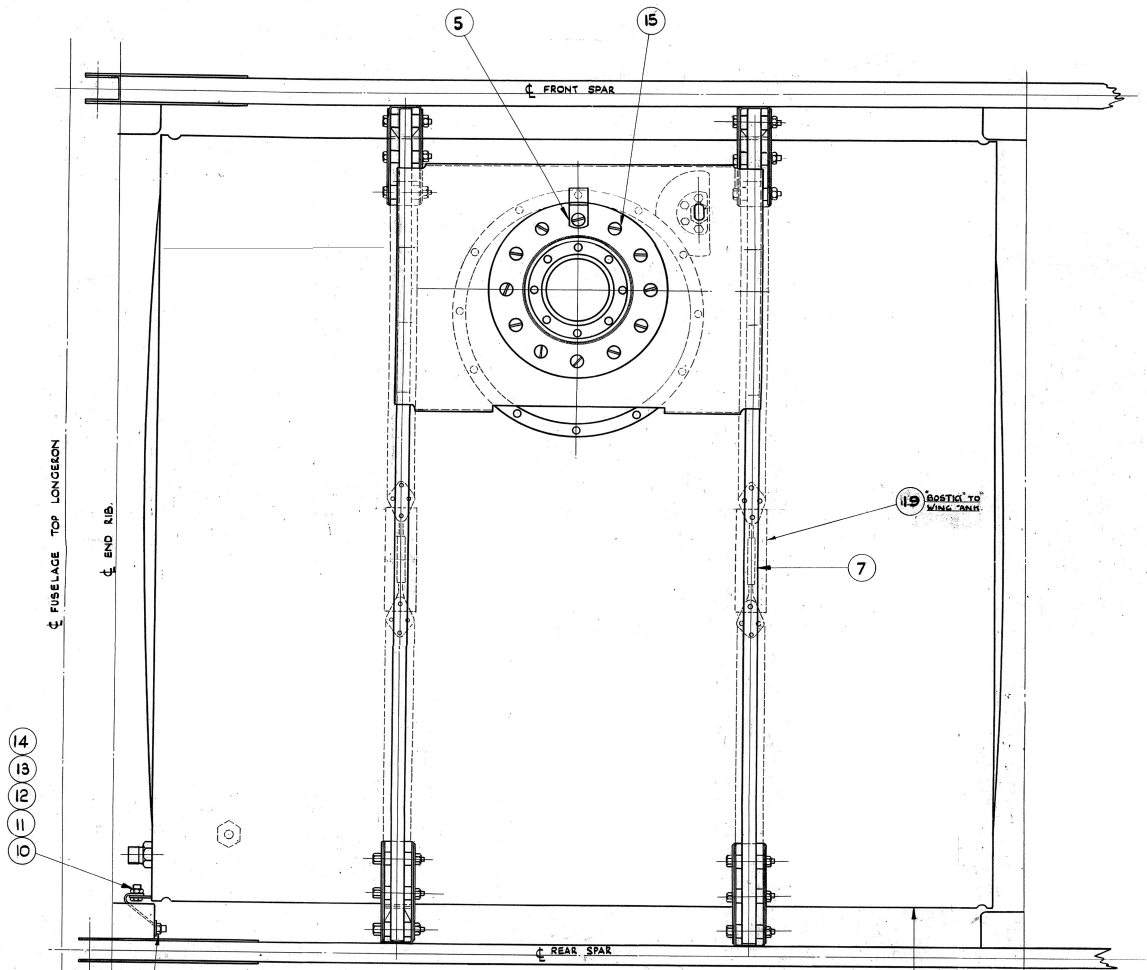

NOTE!
 BONDING LEAD FASTENED TO 4 B.A. BOLT HOLE IN RIB SUPPORT BRKT FLANGE GOOD ELECTRICAL CONTACT MUST BE MADE

NOTE! *
 PART No JL 30882/R - ASSY. IN ST'BD WING AS DRAWN, WITH FILLER CAP, ITEM 4
 PART No JL 30882/L - ASSY. IN PORT WING OPP. HAND, WITH FILLER CAP, ITEM 4
 PART No JL 31554/R - ASSY. IN ST'BD WING AS DRAWN, WITH FILLER CAP, ITEM 10
 PART No JL 31554/L - ASSY. IN PORT WING OPP. HAND, WITH FILLER CAP, ITEM 10
 PART No JL 31905/R - ASSY. IN ST'BD WING AS DRAWN WITH FILLER CAP ITEM 6
 PART No JL 31905/L - ASSY. IN PORT WING OPP. HAND WITH FILLER CAP ITEM 6

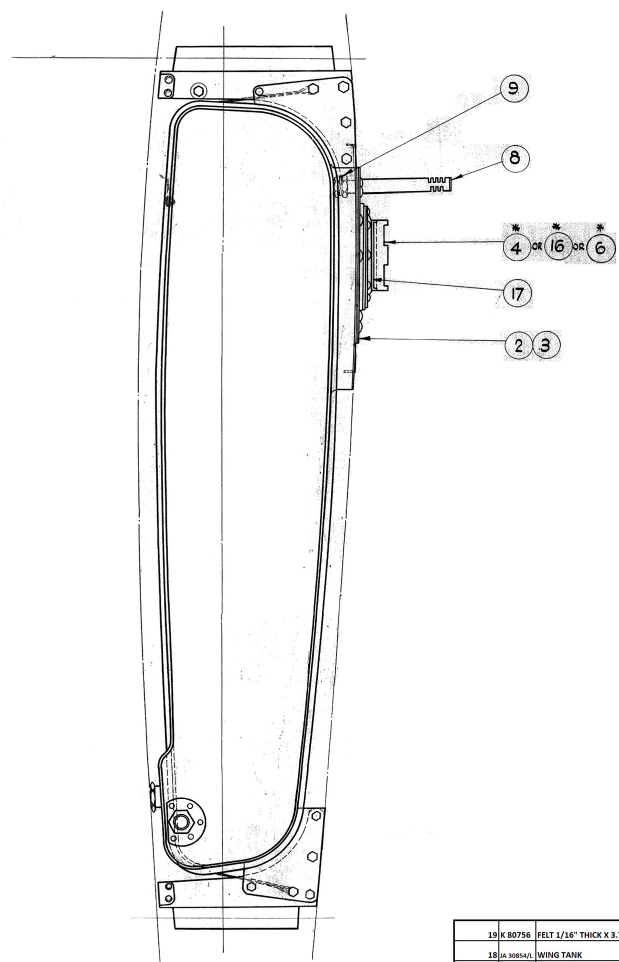
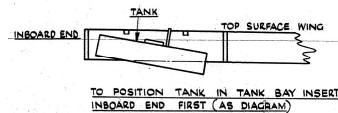

19	K 80756	FELT 1/16" THICK X 3.75" LONG		2 LH/RH
18	JA 30854D	WING TANK	EJC 438/L	1 LH
17	A65 65076	RING LOCKING		1 LH/RH
16	J 31546	FILLER CAP	AJC 470	1 LH/RH
15	AS 12482/C	BOLT		12 LH/RH
14	A65 20018	STIFF NUT		2 LH/RH
13	A65 16226	SPRING WASHER		2 LH/RH
12	DA 90	BONDING LEAD	ADC 137	1 LH/RH
11	A65 14678	WASHER		1 LH/RH
10	A62/3B	BOLT		2 LH/RH
9	A65 5678	WASHER		1 LH/RH
8	KA 3968	VENT TUBE ASSEMBLY	AKC 68	1 LH/RH
7		LOCKING WIRE 20 G	SOFT IRON	AS REQ.
6	J 31924	FILLER CAP	AJC 470	1 LH/RH
5	K 30817	BONDING CLIP	AKC 330	
4	J 30961	FILLER CAP	AJC 470	1 LH/RH
3	K 80819	CAPPING RING	AKH 282	1 LH/RH
2	K 80818	WASHER	AKH 281	1 LH/RH
1	JA 30854/D	WING TANK	EJC 438/R	1 RH

PROTECTIVE TREATMENT	ASSY. NO.			ITEM NO.			PART NO.	DESCRIPTION	MATERIAL OR DRG. NO.	NO. OFF.
	CJC 474	CJC 908	ASK 2317							
	DIC 701	EJF 404 SHT	JASK 2314							
SCALE: 1: 2										
DRAWN								CHECKED		TRACED
AUSTER AIRCRAFT LTD. REARSBY, LEICESTER								STRESS		PART NO. SEE TABLE
TITLE: WING TANK (ASSY TO WING)										DRG. NO. EJC 455

J	ENCL	3437	
H	MOD	3312	
G	APP	2503	
F	CHK	2507	REP
E	CHK	2826	REP
D	CHK	2278	REP
C	CHK	1964	REP
B	CHK	1751	

TYPE: JS B, G, H & JS CONN. J/SF